



# DATA SHEET

## SSS-86



### Solid State Loadswitch:

#### **Description:**

The PDC SSS-86 Solid State Loadswitch is a tri-pack solid state relay package designed specifically for the Traffic Control Industry. This unit meets NEMA specification TS1-1983, section 5.

Each switch will turn it's rated load ON or OFF within 10 deg. of the first zero cross-over point & within 5 deg. on succeeding alterations randomly timed input command signal.

The electronics are enclosed in a dust resistant, metal enclosure providing mechanical protection and excellent heat sinking for the heat generating components in the circuit. The electronic components are easily accessible by removing the cover with a screwdriver.

#### **Installation:**

The switchpac inter mates with any standard NEMA loadbay or with the model 332 cabinet output file. It is easily installed or removed by grasping the handle. Connector P1 pin outs are shown in FIG 1. The connector mates with a PDC BCS-12 or equal.

PIN	FUNCTION	P1
1	+115VAC, 60 Hz	(P1 as viewed from the outside of the product looking directly at the connector)
2	Chassis Ground	
3	A Output (Red, Don't Walk)	
4	Not Assigned	
5	B Output	
6	A Input (Red, Don't Walk)	
7	C Output (Green, Walk)	
8	B Input (Yellow)	
9	+24 VDC	
10	C Input (Green, Walk)	
11	Not Assigned	
12	Not Assigned	

FIG 1.

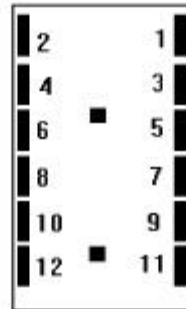

#### **General Characteristics:**

Load	voltage.....120 VAC
	current (max)..... 15.0 Amps (Tungsten)
Filament Load)	
Control Signal	voltage..... +24VDC
	current ..... 20.0 MA (max)
Switching	1st alternation after..... $\pm$ 10 Degrees of line
voltage at the zero	signal is applied. crossover point.
	Succeeding alterations..... $\pm$ 5 Degrees of line voltage at the zero crossover point.
Off State	dv/dt.....100 V per microsecond
	line to load resistance.....15 K Ohms Min
	leakage current.....less than 20 MA
Isolation	voltage.....2500 VDC Min
	resistance.....10 Meg Ohms Min
Surge Current	one cycle.....175 Amps RMS Min
	one second.....40 Amps RMS Min
Life	operations.....30 million Min
Mechanical	length.....8.40 inches
	width.....1.74 inches
	height.....4.185 inches
	weight.....1.135 LBS

**Guarantee:** The SSS-86 is fully guaranteed against all failures due to manufacturing defects for two years.

**Adjustments:** The switchpac has no adjustments



# DATA SHEET

## SSS-86

### Theory of operation:

**General** - The switchpac is an AC zero voltage switch which can be broken down into three (3) separate functions. The functions are illustrated in Fig 2.

**Input** - The input circuit is analogous to the coil of an electromechanical relay. CR1 is a reverse voltage protection diode. CR2, CR3, CR4, R1, R5, & R10 provide the proper voltage range for switch turn on.

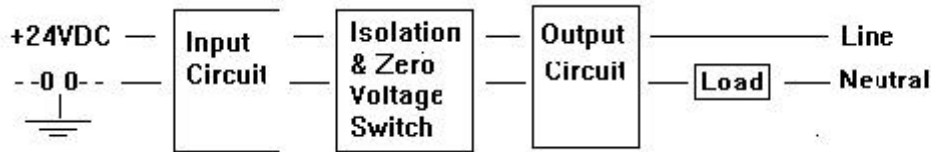

**Isolation & Zero Voltage Switch** - Isolation and zero voltage switching is performed by IC1, IC2, & IC3 which are optically isolated zero voltage turn on triacs.

**Output** - The output circuit consists of a triac and the load circuit. The triac is a simple bi-directional switch whose on - off state is controlled by the zero voltage switch circuit.

### Detailed Description of Circuit Operation

See above "Theory of Operation"

### Maintenance:

If the switchpac does not function properly, follow the outline I and II to isolate the problem.

#### I. Perform the following preliminary checks:

- A. Check for 115VAC and 24 VDC at the input of switchpac.
- B. Check the control signal input circuit (which is part of the traffic control system)
- C. Check switchpac wiring external to P1.
- D. Check for burned out load lamp.
- E. check for broken component leads inside the switchpac.

II. If steps A through E of outline I are normal, the problem is within the switchpac. Select either problems 1 or 2 depending on the fault condition present. For example purposes, the isolation procedures shown in problem 1 assumes that the load A section of the switchpac is faulty.

#### A. Problem 1.

Switchpac stays on all the time, even in absence of a control signal.

Probable Cause - Either IC1 or TR1 is shorted.

Isolation Procedure- Remove one side of R3. If switchpac is still shorted change TR1. If not, change IC1.

#### B. Problem 2.

Switchpac does not turn on when signal is applied.

Probable cause - I1, CR2, IC1, or TR1 is open. If TR1 is open, R2 would be burnt.

Isolation Procedure-

1. Lift one side of R1 and put ammeter in series. Switchpac should draw approximately 20MA. If current measures approximately 20MA, change IC1.
2. If no current, then jumper CR2. If current flow is over 20MA, change CR2.
3. Jumper I1. If current flow of 20MA or more, change I1.
4. Measure resistance of R1. If it is not 510 ohms, change R1



# DATA SHEET

## SSS-86

SSS-86-3 Partslist

Assembly NO. 00239

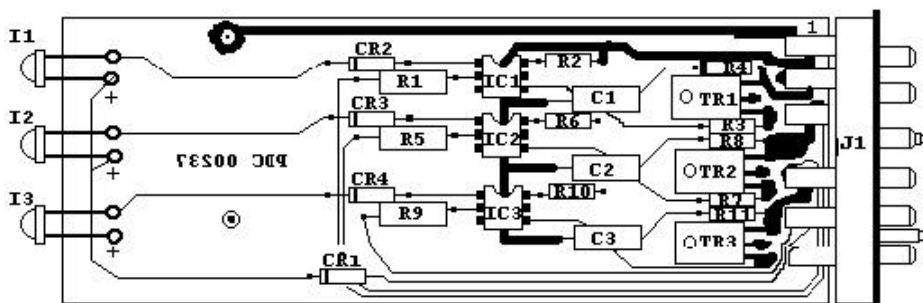
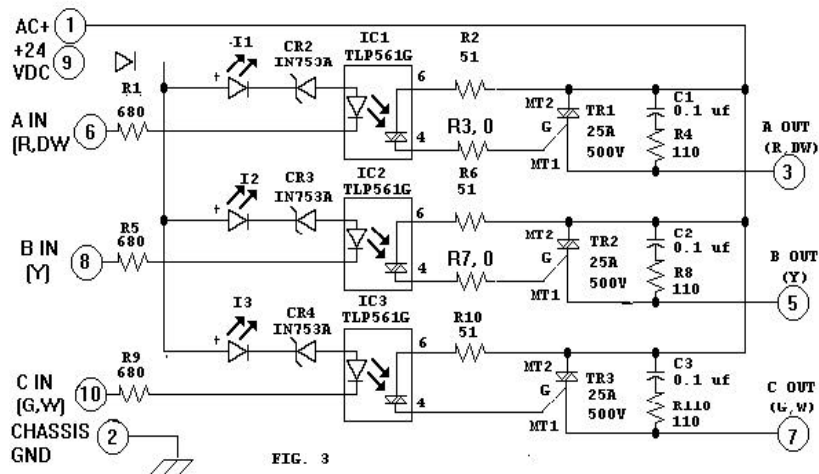

Item No.	QTY	DESC.	PDC PN	MFG	MFG PN	REF DES
1	1	Label,S/N	00043	PDC	00043	
2	1	Chassis	00204	PDC	00204	
3	1	Cover	00206	PDC	00206	
4	1	Bar, Triac	00212	PDC	00212	
5	1	Label, Front	00214-1	PDC	00214-1	
6	1	PC Board	00237	PDC	00237	
7	3	Cap .1uf 400v	CO003	Thomson	MC104K4G	C1,2,3
8	3	Diode, 1N753A, Zener	CR0005	Fairchild	1N753A	CR2,3,4
9	1	Diode, 1N914	CR0007	Fairchild	1N914	CR1
10	2	Spacer	H0015			
11	3	Nut, 6-32	H0038			
12	4	Screw, #5x3/8	H0040			
13	2	Screw, 6-32x3/8	H0041			
14	3	Screw, 6-32x15/16, Fill	H0042			
15	2	Screw, 6-32x1 3/16	H0043			
16	3	Opto Triac	IC0023	Sharp	S21MD4	IC1,2,3
17	1	Conn, 12 pin	J0002	Beau	P5412-S	J1
18	3	L.E.D.	LD0004	G.I.	MV5020	I1,2,3
19	3	Res, 680 ohm 1/2W	R0004	Dale		R1,5,9
20	3	Res, 2.2K ohm 1/4W	R0010	Dale		R2,6,10
21	2	Res, 0 ohm	R0052	Dale		R3,7
22	3	Triac, 500V, 25Amp	TR0012	Teccor	Q5025LX	TR1,2,3