



# DATA SHEET : SSF-88



## **Solid State Flasher:**

### **Description:**

The PDC model SSF-88 solid state flasher is a dual circuit flasher designed for the Traffic Control Industry, specifically to meet California Department of Transportation Model 204 specifications. This unit is conservatively rated up to 15 A per circuit. The flash rate is 56.25 flashes per minute and does not vary due to voltage or temperature variations.

### **Installation:**

The flasher intermates with the model 332 cabinet. It is easily installed or removed by grasping the handle. Connector pinouts are shown in FIG 1. The connector mates with a Beau P-5406-LAB or equivalent.

FIG 1.

Pin	Function
7	Load #1
8	Load #2
9	Chassis ground
10	AC-
11	AC+
12	Spare

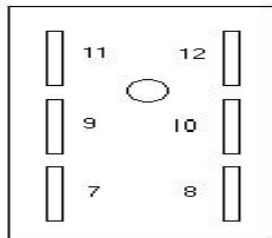

## **General Characteristics:**

Load	Voltage.....	120 VAC
	Current (max).....	15.0 Amps (Tungsten filament load)
Flash Rate	Flashes /min.....	56
	Duty cycle.....	50%
Switching	1 <sup>st</sup> alteration after signal is applied	+10 degrees of line voltage
	.....	Zero crossover point
	Succeeding alterations.....	+5 degrees of line voltage
Off State	Dv/dt.....	100 V per microsecond
	Line to load resistance.....	15K ohms min.
	Leakage current.....	Less than 20 MA
Isolation	Voltage.....	2500 VDC min.
	Resistance.....	10,000 meg ohms min.
Surge Current	One cycle.....	175 Amps RMS min.
	One second.....	40 Amps RMS min.
Life	Operations.....	30 million min.
Mechanical	Length.....	8.40 inches
	Width.....	1.70 inches
	Height.....	4.185 inches
	Weight.....	1.5 lbs

Adjustments: The model SSF-88 flasher has no adjustment controls.



# DATA SHEET : SSF-88

## Theory of Operation:

General – The model SSF-88 flasher can be broken down into three functions, as shown in FIG 2.

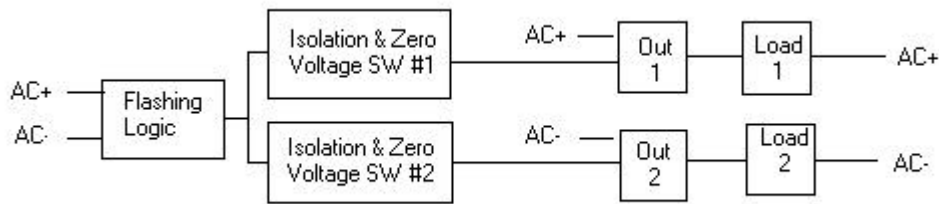

FIG 2.

Flashing Logic – the flashing logic circuit counts the incoming AC line and switches control between circuits 1 and 2, one each ½ second.

Isolation & Zero Voltage Switch – This portion of the flasher is an optocoupler which provides a high degree of electrical isolation between the input signal and the output triac. A LED light source within the optocoupler is used to switch on a photo-triac. The optocoupler contains the zero voltage switching circuitry which turns the output triac on or off within five degrees of the line voltage zero voltage point.

Output – The output circuit consists of a triac and the load circuit. The triac is a simple bi-directional switch whose on-off state is controlled by the zero voltage switch.

## Detailed Description of Circuit Operation:

Referring to the schematic diagram, FIG 3., the flashing logic circuit consists of C1, C2, C3, CR1, R2, R3, R5, R12, IC1, Q1, Q2, & Q3. The flashing logic circuit is a free running circuit as long as the AC+ is applied. The heart of the flashing logic circuit is the 4024 (7 stage cmos counter) IC1. IC1 counts the AC line presented at pin1 via the components C2, R3, & C3. IC1 counts the AC on pin 1 and every 32 counts changes the status of the output at pin 4 (533 m sec.) When pin 4 is in the (+) state Q# is energized activating circuit #1. When pin 4 is at ground, Q2 activates circuit #2. The output of the flashing logic circuit drives 2 identical optocouplers (IC2 & IC3). When Q3 saturates, IC3 switches on due to the current flow through its photo diode. The photo triac in IC3 has a zero voltage sense circuit built in which will allow the photo triac to turn on or off only within 5 degrees of 0 volts on the AC sine wave. When the photo triac turns on the main power triac TR2 is turned on. TR2 will remain on until the photo triac turns off. I1 & I2 are LEDs that come on with their respective outputs.

Note that regardless of when the input signal (GND) is applied or removed the load is not switched on or off until the pulsating AC voltage drops to zero. With an incandescent lamp load the line voltage and current are in phase and the possibility of RFI due to switching transients is reduced drastically because actual load switching occurs at nearly zero voltage and current. The zero voltage switching action also helps reduce the surge current as the tungsten filament is turned on.

## Maintenance:

Preventative Maintenance: The flasher may be stored in any non-corrosive environment until needed. Once installed and operating the flasher unit needs no preventative maintenance during normal operation.

Trouble Analysis: If the flasher does not operate properly, follow outline I., II., and III to isolate the problem.

- I. Perform the following preliminary checks:
  - A. Check for 115 VAC at the input of the flasher.
  - B. Check for 115 VAC flashing on pins 7 & 8 of the flasher connector (while flasher is operating).
  - C. Check flasher indicators
  - D. Check flasher wiring external to P1.
  - E. Check for burned out load lamp.
  - F. Check for broken wires or component leads inside the flasher.
- II. If steps A through D of outline are normal, the problem is within the flasher. Select either problems 1 or 2 depending on the fault condition present. For example purposes the isolation procedures shown assume that load #1 section of the flasher is faulty.



# DATA SHEET : SSF-88

- A. Problem 1 – Load #1 stays on all the time & load #2 flashes normally.  
Probable cause – TR2, IC3, or Q3 is shorted on.
    - 1. Isolation procedure :
      - a. Disconnect gate lead to TR21 and one end of R14. If load stays on, TR2 is shorted. Replace TR2. If the load turns off, reconnect R14.
      - b. Disconnect one end of R4. If load stays on, IC3 is shorted. Replace IC3. If the load turns off then Q3 is shorted. Replace Q3.
  - B. Problem 2 – Load #1 does not turn on.
    - 1. Probable cause – either TR2, IC3, or Q3 is open.
    - 2. Isolation procedure:
      - a. Jumper pins 4 & 6 of IC3. Output should come on solid. If output stays off TR2 is open. Replace TR2. Remove jumper.
      - b. Jumper Q3 collector to emitter. Output should come on solid. If output stays off, IC3 is open. Replace IC3. If output comes on Q3 is open. Replace Q3.
- III. If the flasher has an erratic flash rate or no flashing outputs the problem is in the logic section of the flasher. Select either problem 3 or 4 depending on the fault condition present.
- A. Problem 3 – Flash rate erratic.
    - 1. Probable cause – IC1 or C1
    - 2. Isolation procedure:
      - a. Check DC power at C1. Voltage levels should be between 8 & 18 volts (see waveform a). If voltage levels are proper proceed to step 3, if not, change C1.
      - b. Check output of IC1, pin 4 (see wave form b). If output is not 533 milliseconds change IC1.
  - B. Problem 4 – No flashing outputs.
    - 1. Probable cause – C1, CR1, IC1 & C2.
    - 2. Isolation Procedure:
      - a. Check DC power at C1. Voltage levels should be between 8 & 18 volts (see wave form a)
        - i. If waveform is proper proceed to step 3.
        - ii. If voltage is zero change CR1
      - b. Check output of IC1, pin 4.
        - i. If the output is not changing, replace IC1.
        - ii. If after changing out IC1 the output is changing, then replace R4.

### Trouble Shooting Sequence Chart:

	Problem	Solution
A	No flashing output	Try another flasher to verify if the flasher is defective. If still no output go to trouble analysis section I. If output then go to trouble analysis section III.
B	Only one circuit flashing	Try another flasher to verify if the flasher is defective. If only one circuit is flashing go to trouble analysis section I. If both flash then go to trouble analysis section III.
C	One output stays on all the time	Try another flasher to verify if the flasher is defective. If output stays on go to trouble analysis section I. If output flashes normal go to trouble analysis section II.

Wave Forms

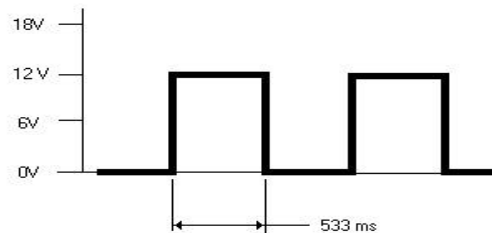
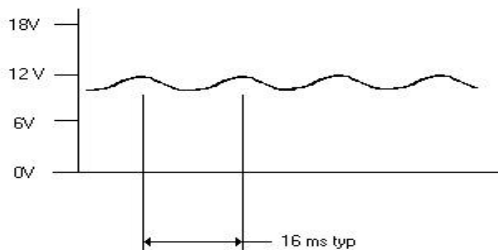

Q )

Voltage Measurements: Voltage measurements are shown under “Maintenance” section I.



# DATA SHEET : SSF-88

Alignment procedure: There is no alignment procedure required for the operation of the flasher.

Guarantee: The flasher is guaranteed against all failures due to manufacturing defects to two years.

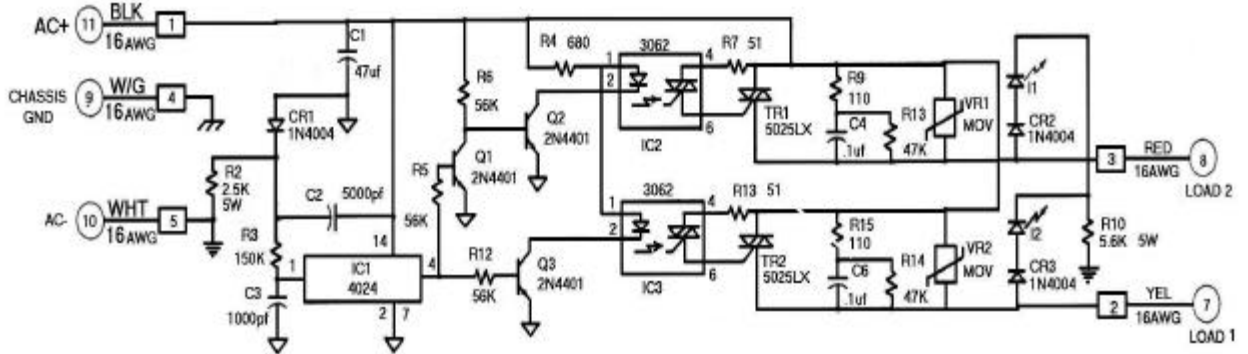
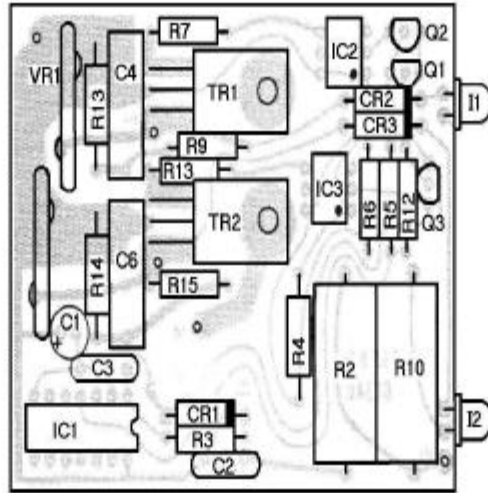

SCHEMATIC DIAGRAM



## DATA SHEET : SSF-88

Item	qty	description	PDC P/N	MFG	MFG P/N	Ref Des
1	1	Label, S/N	00043	PDC	00043	
2	1	Chassis	00328	PDC	00328	
3	1	Cover	00206	PDC	00206	
4	1	Bar, Triac Mounting	00212	PDC	00212	
5	1	Label, front panel	00345-2	PDC	00345-2	
6	1	P.C. Board Fab.	00340	PDC	00340	
7	1	Handle	00333-1	PDC	00333-1	
8	1	Bar, handle support	00334	PDC	00334	
9	1	Wire kit, SSF-88	00351	PDC	00351	W1-W5
10	1	Capacitor, 47uf 16V	C0001	Panasonic	ECE16V47	C1
11	1	Capacitor, 5000pf, 1000V	C0002	RMC	.005500V	C2
12	1	Capacitor , 1000pf, 500V	C0013	RMC	.001500V	C3
13	2	Capacitor, .1uf 400V	C0003	Thomson CSF	MC104K4G	C4,5
14	3	Diode, 1N4004	CR0006	Fairchild	1N4004	CR1,2,3
15	2	Spacer, ¼ OD x .165 ID x 3/16 lg	H0062			
16	2	Nut, keps 6-32	H0038			
17	6	Screw, PH PN HD #6 x 3/8	H0064			
18	2	Screw, PH PN HD 6-32 x 3/8	H0041			
19	2	Screw, PH PN HD 6-32 x 1 3/16	H0043			
20	2	Pop Rivet .125 x 3/8	H0063			
21	1	I.C. C'MOS 4024	IC0002	RCA	CD4024BE	IC1
22	2	Opto Triac	IC0023	Sharp	S21MD4	IC2,3
23	1	Connector, 6 pin	J0057	Beau	P5406LAB	J1
24	2	L.E.D. Clear Red	LD0004	G.I.	MV 5020	I1,2,3
25	1	Resistor, 12K ohm ¼ W	R0014	Dale		R6
26	2	Resistor, 56K ohm ¼ W	R0018	Dale		R5,12
27	1	Resistor, 150K ohm ¼ W	R0020	Dale		R3
28	2	Resistor, 47K ohm ½ W	R0024	Dale		R13,14
29	1	Resistor, 680 ohm ½ W	R0025	Dale		R4
30	2	Resistor, 110 ohm ¼ W	R0046	Dale		R9,15
31	2	Resistor, 51 ohm ¼ W	R0051	Dale		R7,13
32	2	Resistor, 5.6K ohm 5W	R0048	TRW	PW5-5.6	R2,10
33	3	Transistor 2N4401	Q0004	G.E.	2N4401	Q1,2,3
34	2	Triac, 25A 500V	TR0012	Teccor	Q5025LX	Tr1,2
35	1	Tie Wrap	TW0001	Panduit	PLT-1M	
36	2	Varistor	VR0001	NEC	NV240D19	VR1

PDC has developed second and third sources for all our purchased parts. Substitute parts are used upon occasion when market conditions do not allow for the first source to be used. A listing of second and third sources is available upon request for any item that is on the above parts list.