

### Features

Meets or exceeds ITE specifications.

Design provides minimum weight but maximum rigidity and strength.

**MATERIAL** -- The housing, door and visor are injection molded of ultraviolet stabilized, pre-colored opaque polycarbonate.

**HOUSING** -- One piece unit with serrations in 5° increments at each end. Each housing has provisions for mounting two terminal blocks and attaching backplates. Housings may be fastened together to make multi-section signals. The 8" and 12" housings can be intermixed to form combination signals.

**DOOR** -- One piece polycarbonate unit equipped with stainless steel hinge pins. Stainless steel thumbscrews hold the door against the housing.

**VISOR** -- The removable twist-on visor is secured to the door with stainless steel hardware. Cut-away, tunnel, and louvered visors are available.

**REFLECTOR** -- A separately hinged, ALZAK® reflector is standard. Glass is also available.

**LENS** -- Conforms to ITE specifications. The standard lens is polycarbonate capable of withstanding illumination by a standard traffic signal lamp without physical distortion. A glass lens is also available.

**LENS GASKET** -- A molded one piece gasket is used to seal the lens to the reflector and door to form a sealed unit.

**LAMP SOCKET** -- Insulated, pre-focused and may be rotated for positioning the lamp filament without using tools.

**POSITIVE POSITIONING** -- Positive positioning and locking is achieved through the use of serrated brackets, mast arm or span wire fittings.



VEHICLE SIGNALS  
(SA POLYCARBONATE)

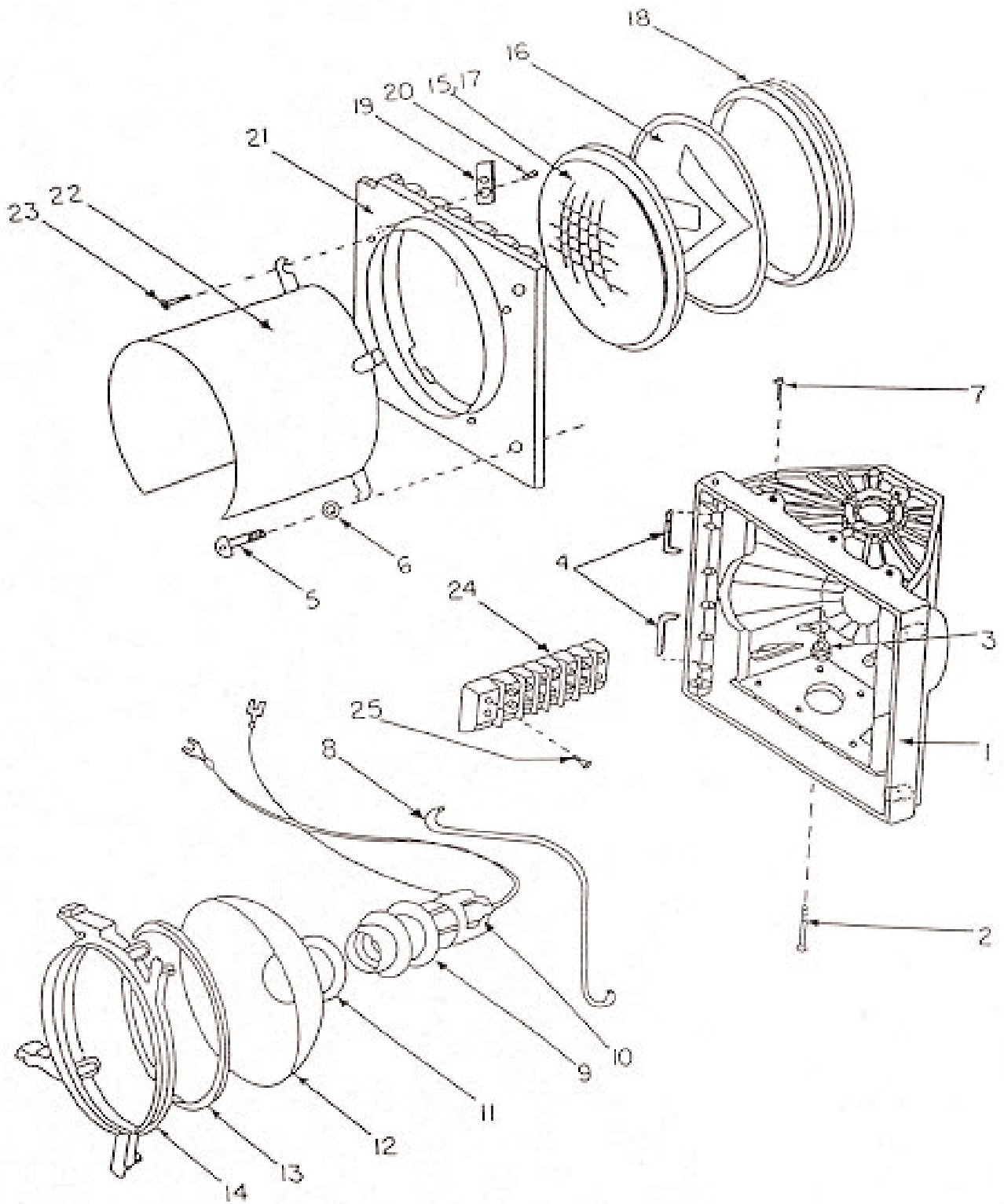

**replacement  
parts  
8" (200mm) &  
12" (300mm)  
traffic signals**

Ref. No.	Description	Part Number	
		8" (200mm)	12" (300mm)
1	Signal housing -- green	KB19113	KB4818
	Signal housing -- yellow	KB19111	KB4816
	Signal housing -- black	KB19112	KB4817
2	Screw (10 - 24 hex screw)	0141716	0141716
3	Flange nut	0150715	0150715
4	Door hinge pin	K1196	K1196
5	Thumbscrew, SS	0141212	0141212
6	Thumbscrew washer, SS	0155924	0155924
7	Hole plug	PHP16	PHP16
8	Socket holder wire (bail)	A701862	A844335
	Bail wire spring	A844337	A844337
9	Socket with brass screw shell	A702029	A702029
10	Lead assy. w/spade lugs, red	A844252	A844252
	Lead assy. w/spade lugs, yellow	A844251	A844251
	Lead assy. w/spade lugs, green	A844250	A844250
11	Socket gasket	A844249	A844249
12	Reflector (glass)	A844244	A844324
	Reflector (alzak)	A844245	A844325
13	Reflector gasket, glass	A701299	A701300
	Reflector gasket, alzak	A844246	A844326
14	Die-cast reflector ring	A702159	A702158
15	Lens, poly - red	PBL240	PBL246
	Lens, poly - yellow	PBL241	PBL248
	Lens, poly - green	PBL239	PBL247
16	Lens, arrow mask	N/A	PBL286
17	Lens, glass - red	PBL3	PBL125
	Lens, glass - yellow	PBL2	PBL124
	Lens, glass - green	PBL1	PBL123
	Lens, glass - red arrow	A844041	PBL234
	Lens, glass - yellow arrow	A844043	PBL233
	Lens, glass - green arrow	PBL114	PBL87
18	Lens gasket	A844248	A844328
19	Lens clip, generic	A84436155	A84436155
20	Lens clip screw	0133029	0133029
21	Signal door, green	PDM2029	PDM2032
	Signal door, yellow	PDM2028	PDM2031
	Signal door, black	PDM2027	PDM2030

Ref. No.	Description	Part Number	
		8" (200 mm)	12" (300 mm)
22	Visor - tunnel	A700119 XX	A700120 XX
	Visor - cutaway	A700468 XX	A700469 XX
23	Visor Screw, SS (10 - 32 x 3/8")	0135021	0135021
24	Terminal block, 6 pos. spade type	PCT100	PCT100
25	Terminal block screw, SS	A702121	A702121

The standard signal is composed of three injection molded polycarbonate body sections containing the optical unit, lens, door and visor. The basic construction design provides minimum weight combined with maximum rigidity and strength. coloring is molded in all the way through, therefore, there is no peeling, no corrosion, and scratches will not show. It meets or exceeds ITS specifications.

**NOTE: VISOR COLOR**

<u>XX</u>	<u>Color</u>
03	Black
04	Yellow
05	Green

**8 in. (200mm) SIGNAL DIMENSIONS**

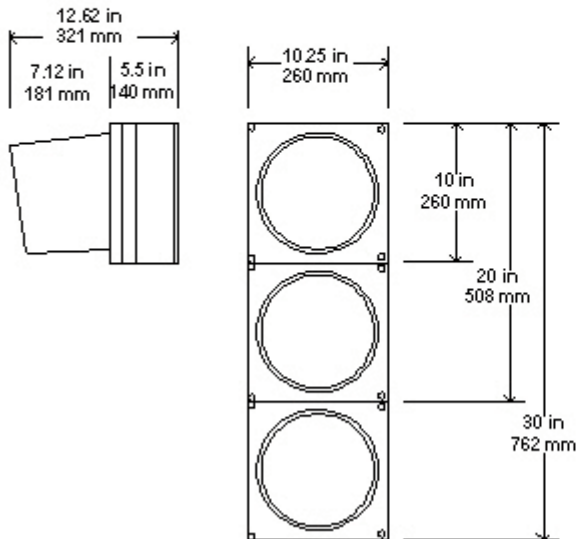

**12 in. (300mm) SIGNAL DIMENSIONS**

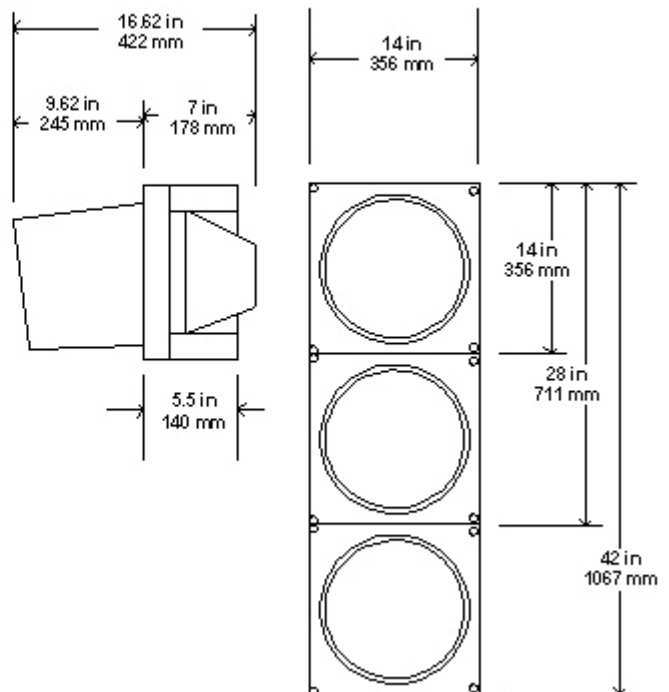

Weights	8" (200 mm)	12" (300 mm)
Single section with visor (approx.)	4 lbs. (1.81 kg)	7 lbs. (3.18 kg)
Housing	1 lbs. 6.4 oz. (.64 kg)	2 lbs. 5.2 oz. (1.05 kg)
Door	7.5 oz. (.21 kg)	15.1 oz. (.43 kg)
Ring	3.5 oz. (.10 kg)	6.6 oz. (.19 kg)