



US00D715672S

(12) **United States Design Patent**
Smith et al.

(10) **Patent No.:** **US D715,672 S**

(45) **Date of Patent:** **** Oct. 21, 2014**

| | | | | |
|---|-------------------|---------|---------------------|---------|
| (54) TRAFFIC CONTROL CABINET | 3,585,456 A * | 6/1971 | Phillips, Jr. | 361/663 |
| | 3,808,504 A | 4/1974 | Rabie | |
| (71) Applicant: Western Systems, Inc. , Everett, WA (US) | 4,218,105 A | 8/1980 | Leighty | |
| | 4,940,299 A | 7/1990 | Lazenby | |
| | 5,082,336 A | 1/1992 | Munch et al. | |
| | 5,806,948 A | 9/1998 | Rowan et al. | |
| (72) Inventors: Michael Charles Smith , Everett, WA (US); Thomas Glen Rivard , Everett, WA (US); Robert Williams Nims , Everett, WA (US) | 6,329,907 B1 | 12/2001 | Uischner et al. | |
| | 6,964,463 B1 * | 11/2005 | Hindle et al. | 312/291 |
| | 7,250,875 B2 | 7/2007 | Schnackenberg | |
| | 7,843,361 B2 * | 11/2010 | Schnackenberg | 340/907 |
| | 8,077,455 B2 | 12/2011 | Jian | |
| | 8,670,224 B2 * | 3/2014 | Little et al. | 361/622 |
| (73) Assignee: Western Systems, Inc. , Everett, WA (US) | 2001/0035701 A1 * | 11/2001 | Holzheid | 312/204 |
| | 2006/0265853 A1 | 11/2006 | Povolny | |

(**) Term: **14 Years**

(21) Appl. No.: **29/490,996**

(22) Filed: **May 15, 2014**

Related U.S. Application Data

(62) Division of application No. 29/415,027, filed on Mar. 6, 2012, now Pat. No. Des. 708,535.

(51) **LOC (10) Cl.** **10-05**

(52) **U.S. Cl.**
USPC **D10/106.95**

(58) **Field of Classification Search**
USPC D10/106.95, 121; 361/663, 662;
312/204, 291; 340/907

See application file for complete search history.

(56) **References Cited**

U.S. PATENT DOCUMENTS

| | | |
|-------------|---------|---------|
| 774,136 A | 11/1904 | Forbes |
| 1,642,533 A | 9/1927 | Beer |
| 2,101,571 A | 12/1937 | Breisch |
| 2,136,558 A | 11/1938 | Manshel |
| 2,774,808 A | 12/1956 | Bullock |
| 2,803,512 A | 8/1957 | Band |

OTHER PUBLICATIONS

United States Patent & Trademark Office; Non-Final Office Action dated Apr. 11, 2014; U.S. Appl. No. 13/624,747; pp. 1-15.

* cited by examiner

Primary Examiner — George D Kirschbaum

(74) *Attorney, Agent, or Firm* — Lane Powell, PC; Priya Sinha Cloutier

(57) **CLAIM**

The ornamental design for a traffic control cabinet, as shown and described.

DESCRIPTION

FIG. 1 is a front view of a traffic control cabinet showing our new design;

FIG. 2 is a front perspective view thereof;

FIG. 3 is a back view thereof; and,

FIG. 4 is a back view thereof.

The broken line showing of handles, vents, a front plate, and internal structures is included for the purposes of illustrating portions of the "article" and form no part of the claimed design.

1 Claim, 4 Drawing Sheets

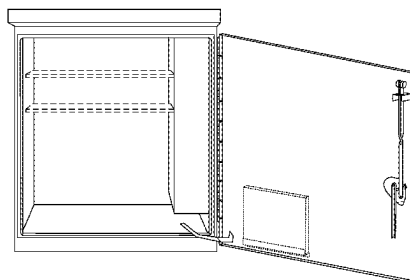
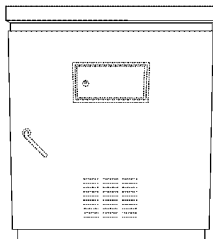

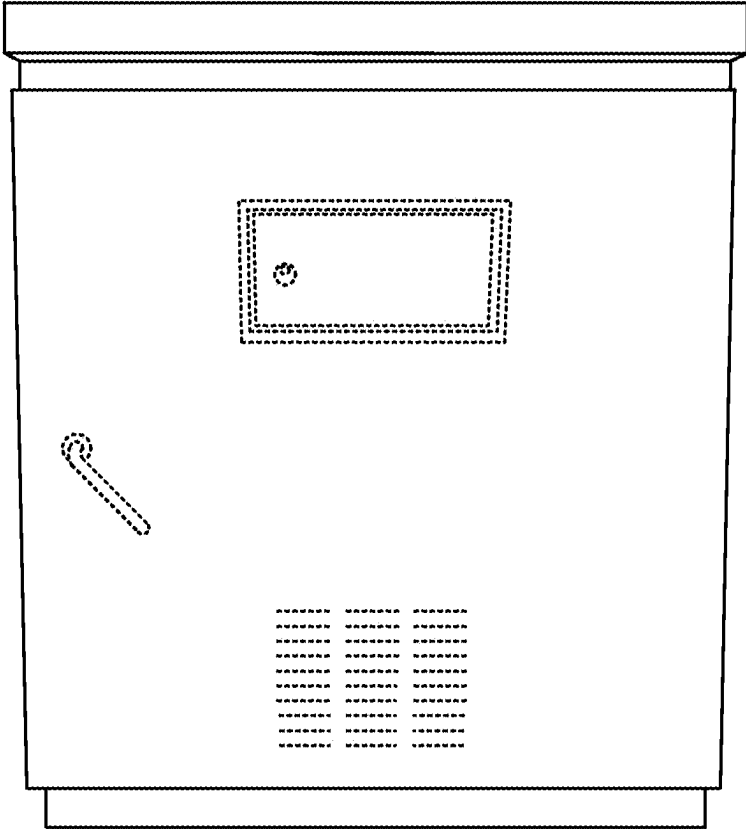

FIG. 1

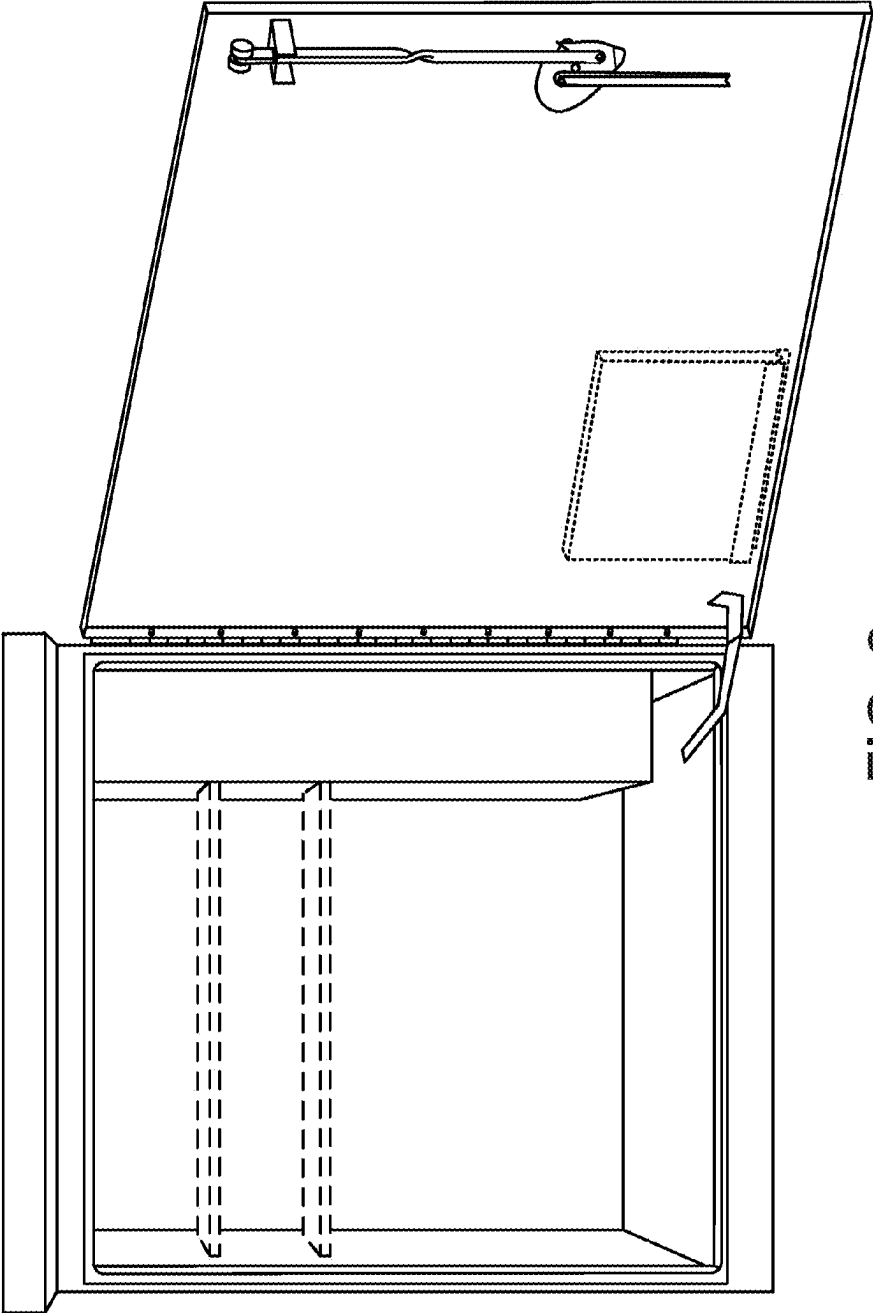

FIG. 2

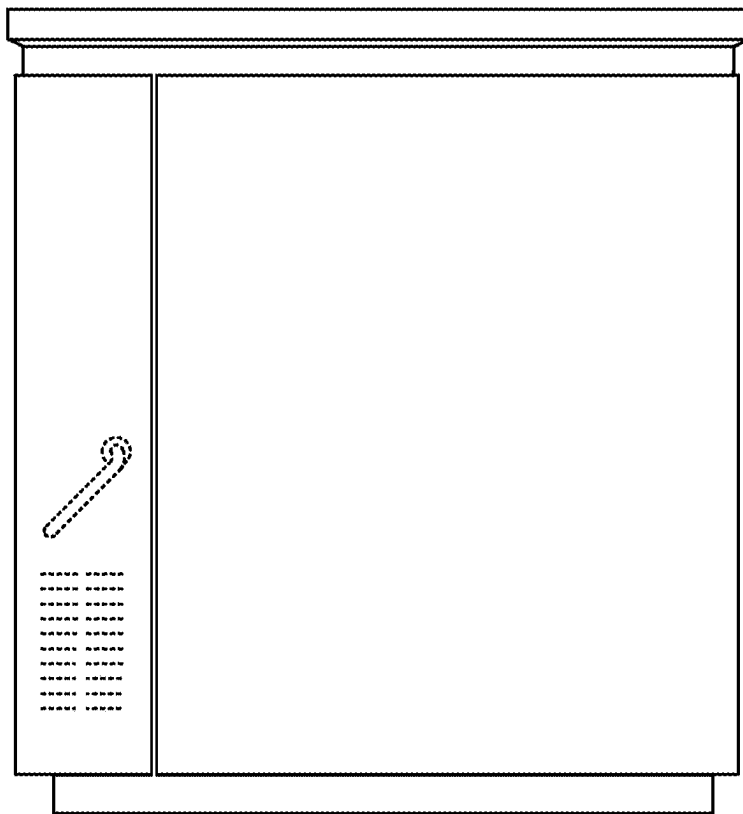

FIG. 3

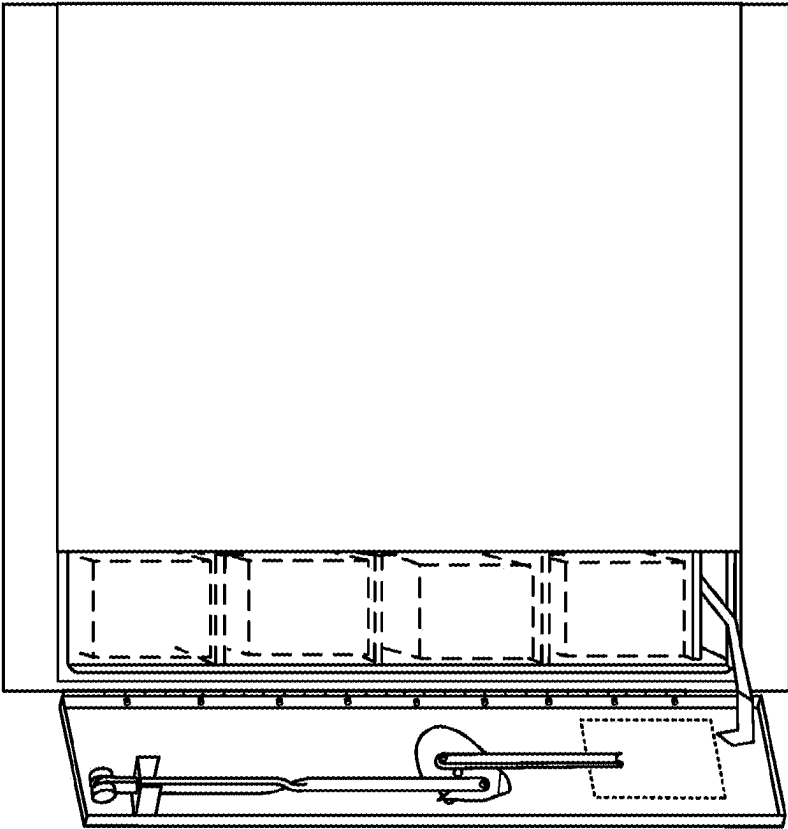

FIG. 4